

IWAKI  
CHEMICAL  
GEAR PUMPS

**GM-V**



# Highly Corrosion-Resistant Sealless Gear Pump

Iwaki's Chemical Gear Pump GM-V is an internal gear pump made of highly corrosion-resistant materials. During pump operation, liquid does not come into contact with any of the pump's metallic parts. A magnet drive mechanism ensures that no liquid solution leaks from the pump. Thus, the GM-V safely handles most corrosive liquid chemicals, including acids and alkalis. Since the GM-V is pulsation-free and features precise discharge output, this pump is ideally suited to metering injection without pulsation.

## Sealless, highly corrosion-resistant design

All pump components in contact with the liquid are made of PVC, silicon carbide and fluorine resin, all of which are resistant to most acids and alkalis. The pump uses no seals, which eliminates the risk of leaks.

## High-durability ceramic gears

The GM-V's ceramic gears are highly resistant to abrasion, galling and seizure, ensuring reliable high-speed operation.

## Pulsation-free and precise discharge control

The GM-V causes no pulsation of liquid in high-speed operation. Discharge is proportional to the pump's rpm speed, which can be precisely controlled

by an inverter (frequency converter), thereby allowing liquid metering, transfer and other treatments.

## Low flow rate, high discharge head and self-priming

The GM-V's low flow rate and high head specification make it suitable for many chemical-injection processes. Self-priming up to 1 meter in height is possible.

Note : Self-priming height varies depending on the liquid's properties and temperature as well as the piping configuration. Please contact your distributor for details on self-priming applications.

## Lightweight and compact

The GM-V's pump is close coupled to its motor, eliminating the need for intermediate coupling and making the assembly both lightweight and compact. The GM-V's space-saving design makes it suitable for built-in pump systems.



GM-25V Flange type



### Operating principle

A pinion (drive gear) coupled with a shaft supported by two bearings meshes with an internal gear (driven gear) whose periphery is supported by a strong bearing. Liquid is transferred by a change in the capacity of this meshed portion. In the suction process, the gears are disengaged and a space defined by the two gears and the casing expands. The liquid is drawn into the space by the negative pressure generated. In the discharge process, their teeth begin to mesh and space defined by the two gears and the casing is reduced to force out the liquid.

### GM-V is useful in the following cases

- **Low flow rate and high pressure applications with chemical solutions**  
Automatic injection of coagulant at a constant mixing ratio.
- **Pulsation-free metering, injection and transfer of chemical solutions**  
Metering of paper-making dye and sodium hypochlorite.
- **Easy control of process factors such as flow rate and pressure**  
Low-cost, reliable control of rpm levels.
- **No need for pulsation dampener or accumulator**  
Simple piping without pulsation is possible.
- **Bypass piping using a large-flow rate centrifugal pump**  
No losses due to bypassing.
- **Excellent corrosion resistance against acids and alkalis**  
Unlike general-purpose gear pumps, the GM-V's metallic components never come into contact with liquids and are acid and alkali resistant.
- **Designed to make diaphragms unnecessary**  
GM-V pumps do not employ any seals or diaphragms.
- **Self-priming**  
Self-priming up to 1 meter in height (when wet) is possible.

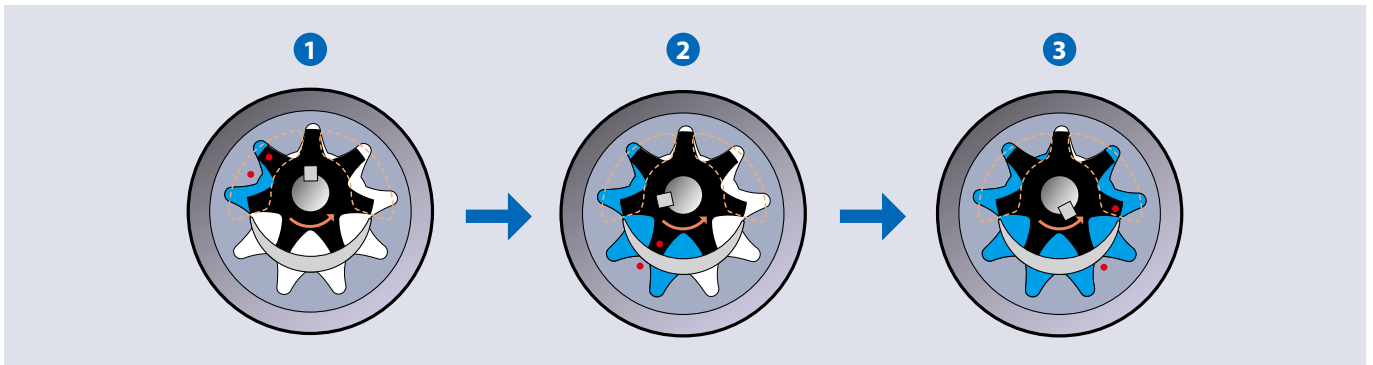

GM-25V Rc connection type  
(IEC Motor Model)

# Highly reliable drive mechanisms

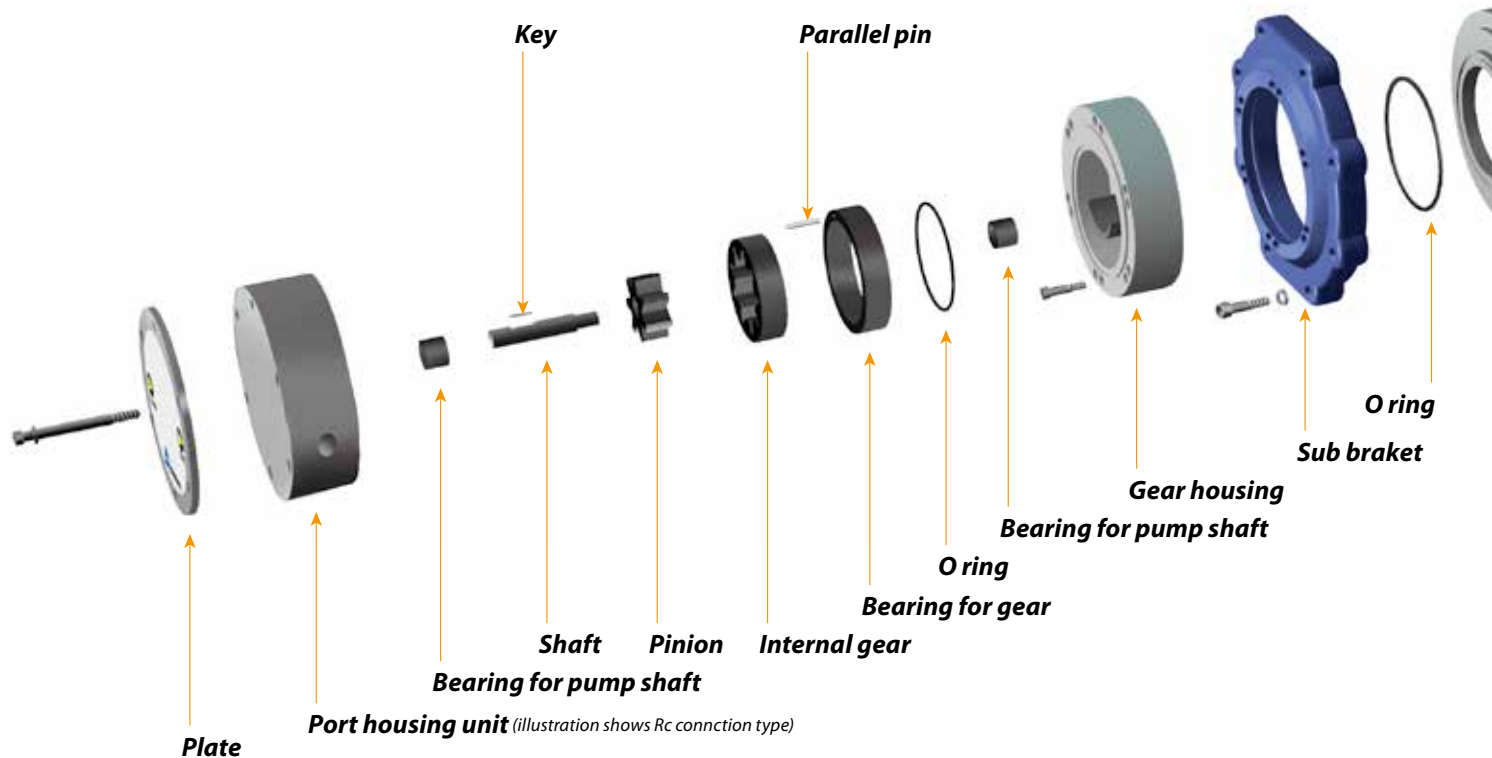

## Wet end materials

Parts	GM-15V	GM-25V
1 Housing (Pump body)	PVC	
2 Rear casing	CFRETFE	
3 Magnet capsule	PVC	CFRETFE
4 Pinion	SiC	
5 Internal gear	SiC	
6 Shaft	Si3N4(Silicon nitride)	
7 Bearing for gear	SiC or Carbon	
8 Bearing for pump shaft	SiC or Carbon	
9 Key	PVC	
10 Parallel pin	Alumina ceramic	
11 Spacer(GM-15V type)	Fluorine resin with filler	—
12 O-ring	FKM or EPDM	
Spindle(GM-25V type)	—	Alumina ceramic or SiC

Note : CFR stands for Carbon Fiber Reinforce.

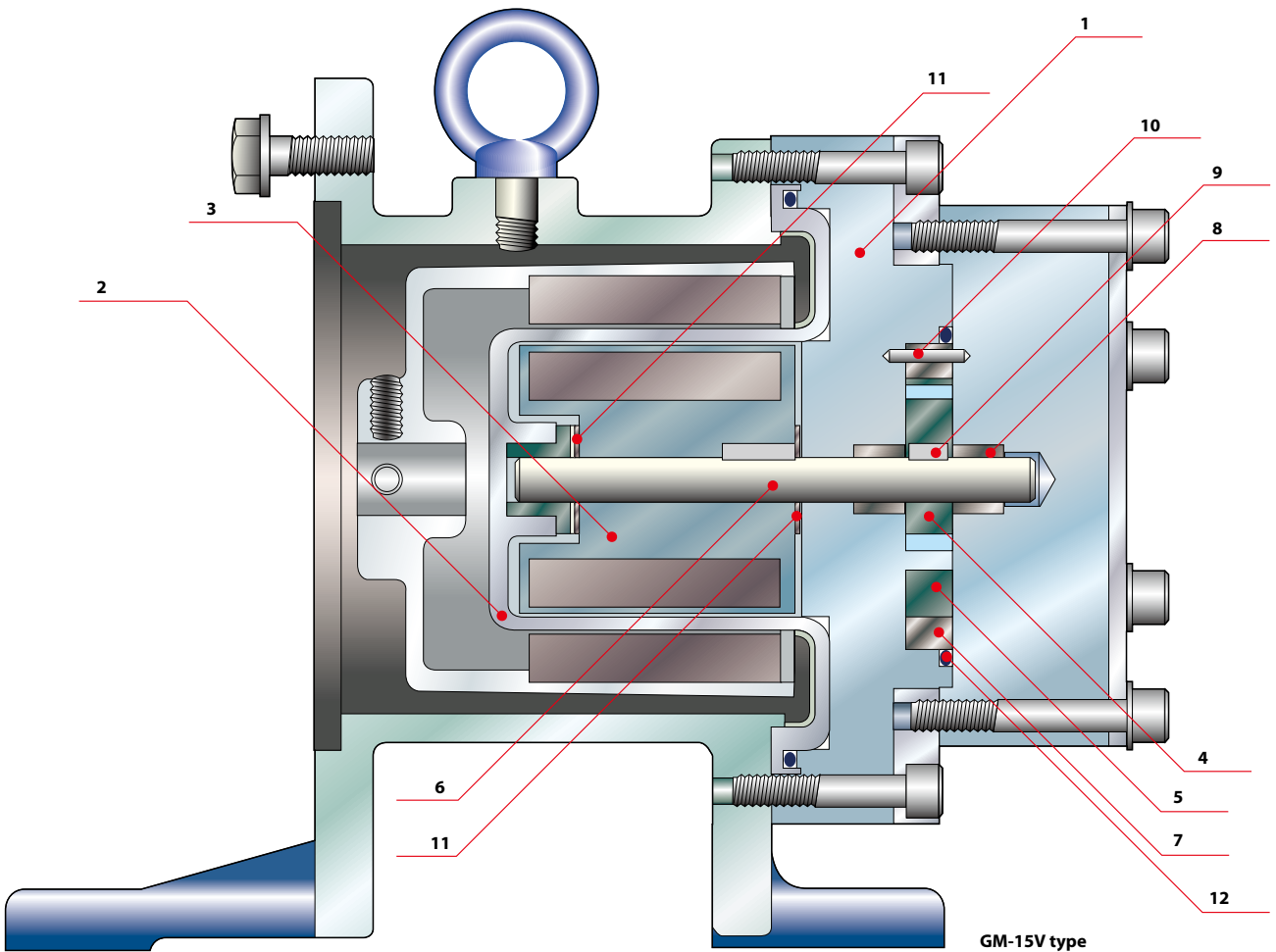
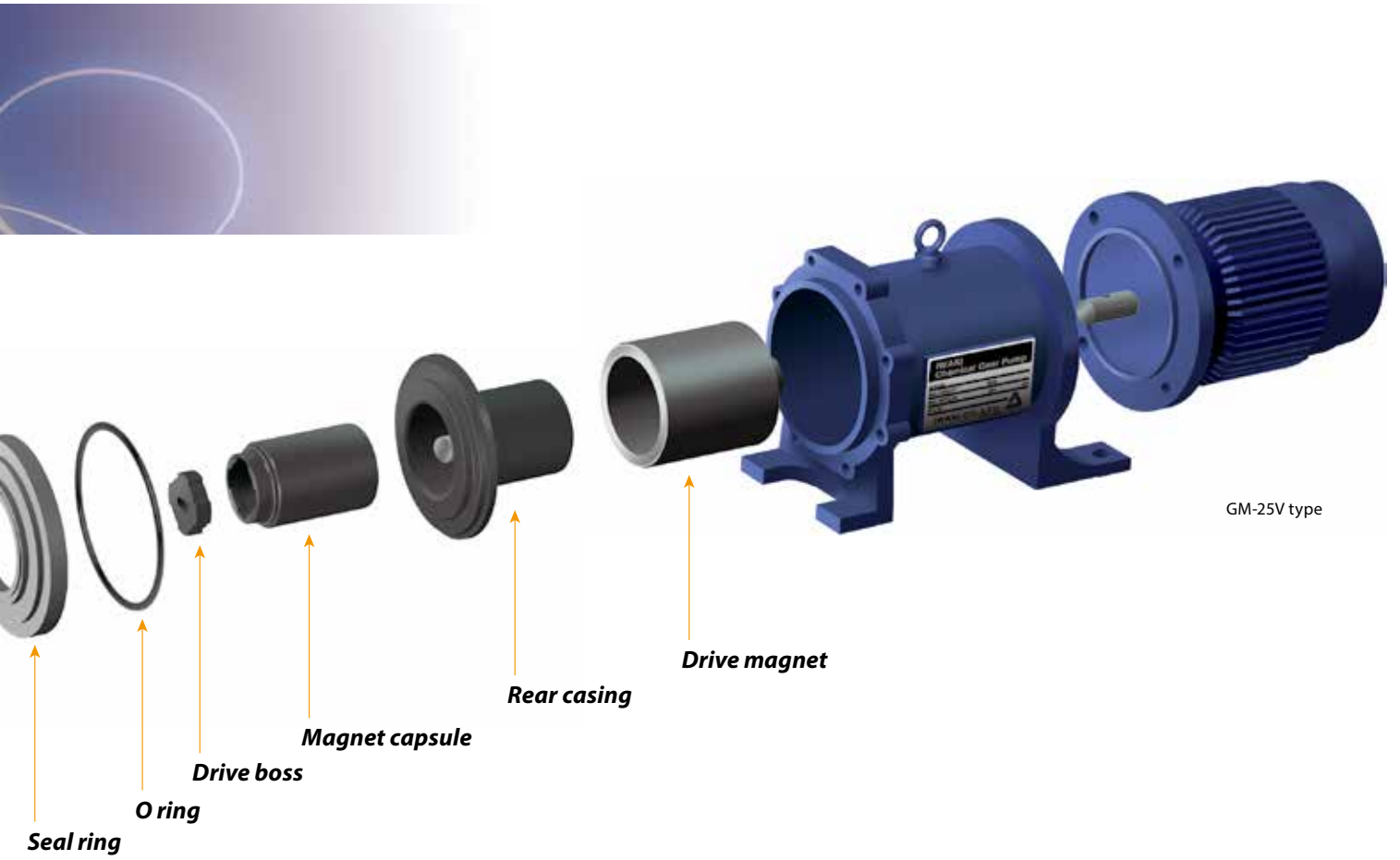

# Pump identification

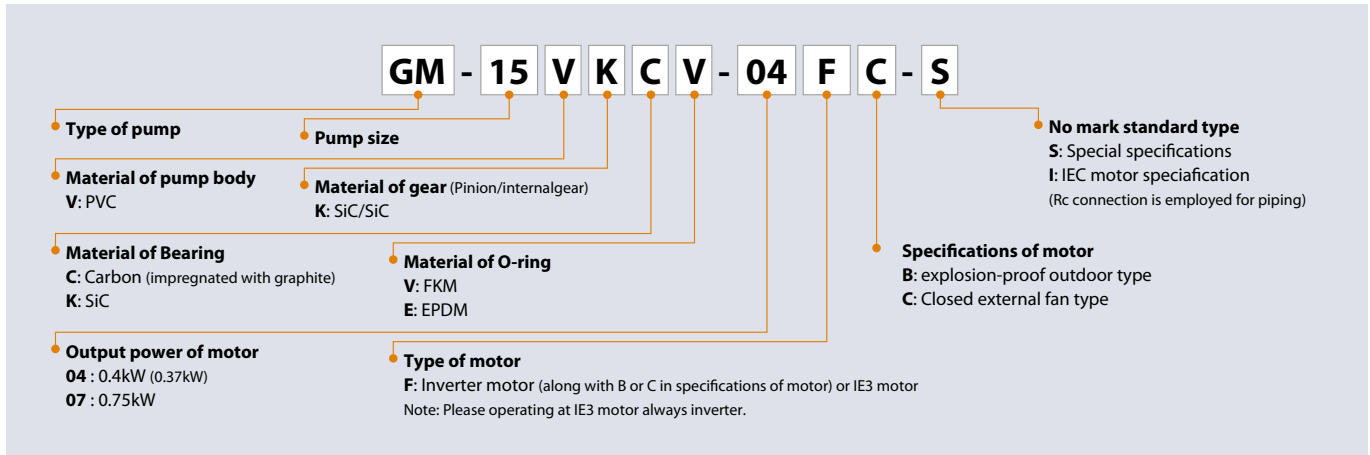

# Specifications

Models	Discharge per revolution mL/rev	Max. Capacity L/min	Max. Speed rpm	Max. Discharge pressure MPa	Connections	Motor kW
		60Hz	60Hz			
<b>GM-15V</b>	3.3	5.9	1,800	0.5	JIS10K 15A or Rc 3/8	0.4(0.37)
<b>GM-25V</b>	12.8	23.0	1,800	0.5	JIS10K 20A or Rc 3/4	0.75

Conditions of liquid to be handled : Temperature = 0°C -50°C / Viscosity = 0.5-50 mPa · S / No slurry can be handled  
 Maximum capacity is achieved at lowest pressure.  
 For a GM-15V to handle a liquid with viscosity of 3 mPa · S or less,  
 the maximum capacity is as follows : 0.28 MPa at 60 Hz for viscosity between 0.5 and 1 mPa · S  
 0.35 MPa at 60 Hz for viscosity between 1 and 3 mPa · S

# Standard pumps

Models	Inverter frequency Hz	Speed rpm	Viscosity mPa · S	Capacity L/min					
				Discharge pressure MPa					
				0	0.1	0.2	0.3	0.4	0.5
<b>GM-15VK</b> □□-04F □	6 to 60	180 to 1800	0.5	0.6 to 5.9	0 to 3.9	0.05 to 1.9	—	—	—
			1		0 to 4.5	0.05 to 3.1	0.05 to 1.7	0.05 to 0.3	—
			3		0 to 5.1	0.05 to 4.3	0.05 to 3.5	0.05 to 2.7	0.05 to 1.9
			50		0.4 to 5.7	0.2 to 5.5	0.05 to 5.3	0.05 to 5.1	0.05 to 4.9
<b>GM-25VK</b> □□-07F □	6 to 60	180 to 1800	0.5	2.3 to 23.0	0.1 to 19.6	0.1 to 16.2	0.1 to 12.8	0.1 to 9.4	0.1 to 6.0
			1		0.1 to 20.6	0.1 to 18.2	0.1 to 15.8	0.1 to 13.4	0.1 to 11.0
			3		0.9 to 21.6	0.1 to 20.2	0.1 to 18.8	0.1 to 17.4	0.1 to 16.0
			50		2.0 to 22.7	1.7 to 22.3	1.3 to 22.0	1.0 to 21.6	0.6 to 21.3

- The flow-rate values given in the above table are for a liquid temperature of 20°C.
- Flow rate varies with liquid temperature. For more details, please ask us.
- To protect pump install strainer and safety valve. 100 mesh strainer is recommended.
- Provided the pump is primed no minimum flow requirement.

## Performance curves

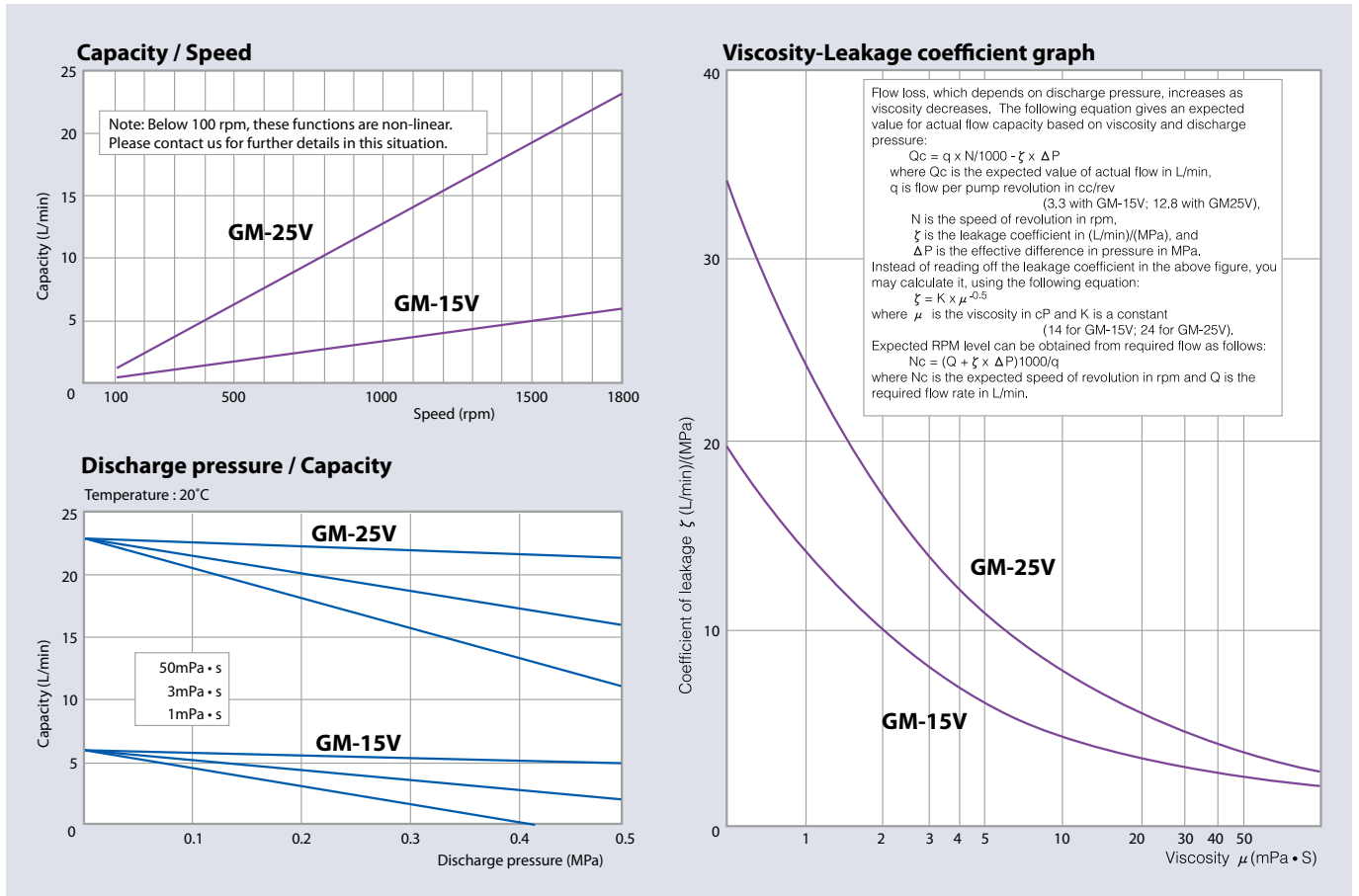

## Dimensions in mm

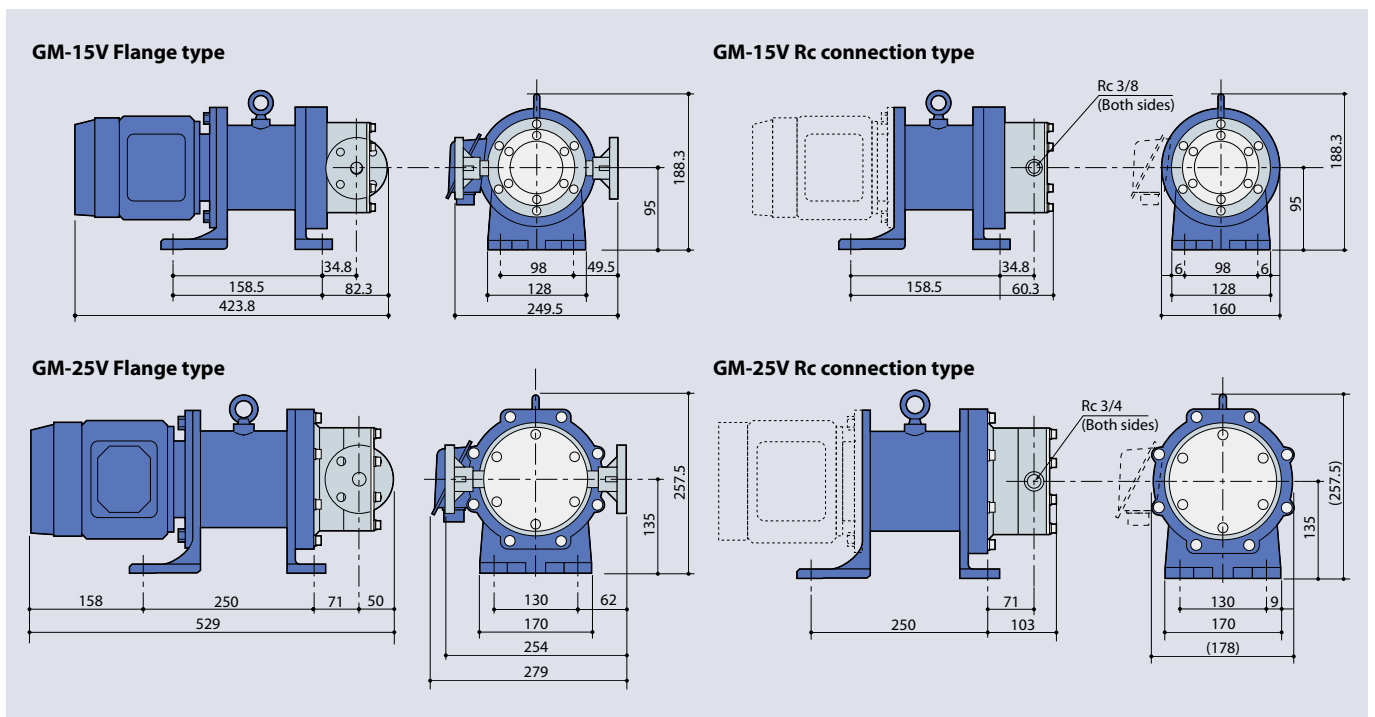

Note: The dimensions may differ with the type of motor installed.





# Fine ceramic have led to exciting innovations.

The Iwaki G series chemical pump is the first internal gear pump designed for chemical process applications, in which gears of fine ceramic (SiC and Silicon nitride) are used. Without detracting from any of the advantages of conventional internal gear pumps abrasion resistance, chemical resistance, low-viscosity characteristics and sealing characteristics have been remarkably improved. In addition to the gland packing/mechanical seal type (Model GX), magnetic drive sealless type (Model GM) are available as standard products for an expanded range of uses. The G series is an advanced gear pump, capable of dealing with a wide range of industrial processes which continue to increase in sophistication.



## Specifications

- Max. discharge capacity : 35.2/42.5 L/min
- Max. discharge pressure : 1.0 MPa(GX type)/0.7MPa(GM type)
- Main materials : SiC/SUS316
- Liquid temp. range : 0 to 150°C(GX type)/0 to 80°C(GM type)
- Viscous liquid : 0.5 to 10000mPa · S(GX type)

**IWAKI CO., LTD.** 6-6 Kanda-Sudacho 2-chome Chiyoda-ku Tokyo 101-8558 Japan TEL : (81)3 3254 2935 FAX : 3 3252 8892

IWAKI has global net work. Please find your distributor location at

[www.iwakupumps.jp](http://www.iwakupumps.jp)

European office : **IWAKI Europe GmbH**  
 Germany : **IWAKI Europe GmbH**  
 Holland : **IWAKI Europe GmbH** (Netherlands Branch)  
 Italy : **IWAKI Europe GmbH** (Italy Branch)  
 Spain : **IWAKI Europe GmbH** (Spain Branch)  
 Belgium : **IWAKI Belgium N.V.**  
 Denmark : **IWAKI Nordic A/S**  
 Finland : **IWAKI Suomi Oy**  
 France : **IWAKI France S.A.**  
 Norway : **IWAKI Norge AS**  
 Sweden : **IWAKI Sverige AB**  
 U.K. : **IWAKI Pumps (UK) Ltd.**

TEL: (49)2154 9254 0 FAX: 2154 9254 48  
 TEL: (49)2154 9254 50 FAX: 2154 9254 55  
 TEL: (31)74 2420011 FAX: (49)2154 925448  
 TEL: (39)0444 371115 FAX: 0444 335350  
 TEL: (34)93 37 70 198 FAX: 93 47 40 991  
 TEL: (45)48 24 2345 FAX: 48 24 2346  
 TEL: (358)9 2745810 FAX: 9 2742715  
 TEL: (33)1 69 63 33 70 FAX: 1 64 49 92 73  
 TEL: (47)23 38 49 00 FAX: 23 38 49 01  
 TEL: (46)8 511 72900 FAX: 8 511 72922  
 TEL: (44)1743 231363 FAX: 1743 366507  
 ( )Country codes

U.S.A. : **IWAKI America Inc.**  
 Argentina : **IWAKI America Inc.** (Argentina Branch)  
 Brasil : **IWAKI Do Brasil Comercio De Bombas Hidraulicas LTDA.**  
 Singapore : **IWAKI Singapore Pte Ltd.**  
 Indonesia : **IWAKI Singapore** (Indonesia Office)  
 Malaysia : **IWAKIm Sdn. Bhd.**  
 Australia : **IWAKI Pumps Australia Pty Ltd.**  
 Hong Kong : **IWAKI Pumps Co., Ltd.**  
 China : **GFTZ IWAKI Engineering & Trading Co., Ltd.**  
 : **IWAKI Pumps (Shanghai) Co., Ltd.**  
 Korea : **IWAKI Korea Co., Ltd.**  
 Taiwan : **IWAKI Pumps Taiwan Co., Ltd.**  
 Thailand : **IWAKI (Thailand) Co., Ltd.**

TEL: (1)508 429 1440 FAX: 508 429 1386  
 TEL: (54)11 4745 4116  
 TEL: (55)19 3244 5900 FAX: 19 3244 5900  
 TEL: (65)6316 2028 FAX: 6316 3221  
 TEL: (62)21 6906606 FAX: 21 6906612  
 TEL: (60)3 7803 8807 FAX: 3 7803 4800  
 TEL: (61)2 9899 2411 FAX: 2 9899 2421  
 TEL: (852)2607 1168 FAX: 2607 1000  
 TEL: (86)20 84350603 FAX: 20 84359181  
 TEL: (86)21 6272 7502 FAX: 21 6272 6929  
 TEL: (82)2 2630 4800 FAX: 2 2630 4801  
 TEL: (886)2 8227 6900 FAX: 2 8227 6818  
 TEL: (66)2 322 2471 FAX: 2 322 2477

**Caution for safety use:** Before use of pump, read instruction manual carefully to use the product correctly.

Actual pumps may differ from the photos. Specifications and dimensions are subject to change without prior notice. For further details please contact us.

**Legal attention related to export.**

Our products and/or parts of products fall in the category of goods contained in control list of international regime for export control. Please be reminded that export license could be required when products are exported due to export control regulations of countries.

The posting and copying from this catalogue without permission is not accepted firmly.